

Model 880-NSL Tail Gas Analyzer

Superior Benefits

- No Sample Line!
- Outdoor installation
- High reliability / low maintenance
- Fast response time
- Extraordinary lamp life
- Automatic zero and span check
- Hot water back-flush for salts removal (optional)
- Self-diagnostic and self-preservation features

Applications

- Sulfur recovery tail gas analysis
 - Claus process
 - Claus with tail gas cleanup
 - Claus with oxygen enrichment

The Need

Accurate, reliable measurement of H₂S and SO₂ in the tail gas from a Claus sulfur recovery plant is critical. Unfortunately, tail gas analysis has historically been one of the most difficult applications because of common problems with sample line plugging due to sulfur vapors present in the sample.

Direct Measurement

AMETEK Western Research, the leader in tail gas analysis for over 25 years, is proud to present the Model 880-NSL (No Sample Line) tail gas analyzer. The Model 880-NSL uses field-proven UV techniques to accurately monitor the H₂S and SO₂ concentrations in the tail gas. This compact, rugged, transmitter-style analyzer mounts directly on your process pipe, eliminating sample line plugging. The 880-NSL is also equipped with anti-clogging blowback features that automatically initiate an air blowback of the analyzer should any internal fault condition occur.

In addition to these reliability-enhancing design features, the 880-NSL comes standard with an extraordinary long-life lamp which will last for up to five years! Reliability is further enhanced as the detector assembly is solid state with no moving parts. The analyzer is also provided with self-monitoring and self-diagnostic features including a calibration filter for performing automatic span verifications.

Both the Zone 1 and Class 1, Div 2 versions of the Model 880-NSL are housed in weatherproof, stainless steel enclosures which are suitable for direct outdoor installation in most parts of the world.



ATEX version of the Model 880-NSL. One of a family of AMETEK analyzer systems for optimizing sulfur removal and recovery.

Model 880-NSL Tail Gas Analyzer

Performance Specifications

Methodology: Non-dispersive ultraviolet
Measurement Range: 0 to 1% SO₂, 0 to 2% H₂S, -1 to 1% excess H₂S typically (0 to 2% SO₂ / 0 to 4% H₂S optional)
Accuracy: H₂S and SO₂: ±2% of full scale
Sensitivity: ±0.15% full scale
Reproducibility: ±1% of full scale
Speed of Response: 90% in less than 15 seconds, typical
Sample Flow: 2 LPM typical
Ambient Temperature: -20°C to 50°C (-4°F to 122°F)
Utilities
Electrical: 120/240 VAC 50/60 Hz 720W, single phase
Instrument Air: 490 to 700 kPa (70 to 100 psig)
Steam Pressure:
 For optional ball valve jacket: 515 to 690 kPa (75 to 100 psig)
 For optional blow back: 210 to 345 kPa (30 to 50 psig)

Outputs
 Three (3) 4-to-20 mA, self-powered, linear, 1200 ohms load proportional to H₂S, SO₂, and either Excess H₂S or Ratio
 One (1) digital, System Alarm incorporates concentration, overrange, system errors, and Watchdog alarm (30 Vac, 60 Vdc, 50 VA, maximum, resistive load)
 One (1) digital, Data Valid Signal (30 Vac, 60 Vdc, 50VA, maximum, resistive load)
 RS-485 Serial Communication Port, half duplex, two-wire
Inputs
 One (1) digital input for remote auto calibration, contact closure, 5 Vdc @ 2.5 mA
 One (1) digital input for remote blowback, contact closure, 12 Vdc @ 100 mA
 Note: Provide isolated contact closure only. Do not apply voltage.
Digital Communication: RS485 serial port. Remote dial-in capabilities available with AMETEK Western Research software

Noise: ±0.5% full scale
Zero Drift: Less than ±0.5% of full scale in 24 hours through periodic automatic zero standardization using instrument air
Calibration: Automatic with span filter, manually operated from the controller
Process Sample Pressure: Not critical
Customer-Supplied Items: 2 in.-150 lbs. or DIN equivalent RF stainless steel flange connection
Enclosure Material: 316 stainless steel
Approvals and Certifications
 UL/CSA General Safety Requirements
 UL/CSA Class I, Division 2, Groups A, B, C, D
 ATEX II 2 G, EEx p mde [ib] IIC T3
 Complies with all relevant European directives
Physical Dimensions: (H x W x D): 950 x 1037 x 305 mm (37.3 x 41 x 12 inch)
Approximate Weight: 115 kg (250 lbs.)

MM
(IN)

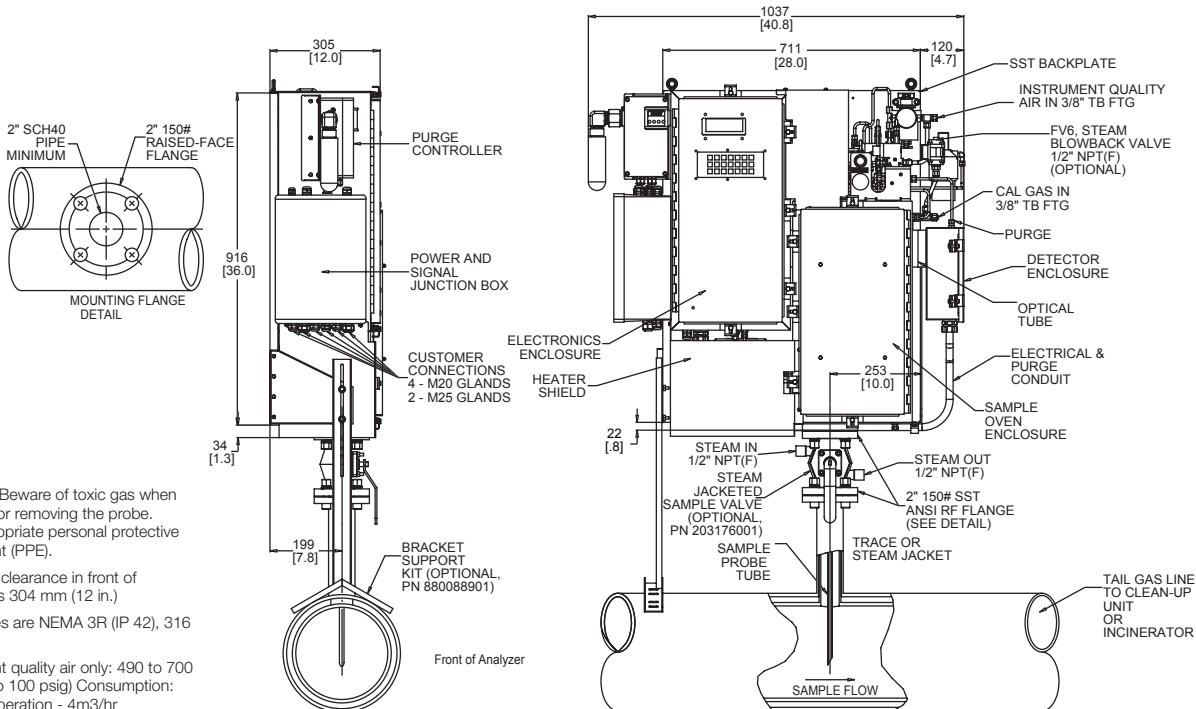

NOTES:

- Warning: Beware of toxic gas when installing or removing the probe. Use appropriate personal protective equipment (PPE).
- Minimum clearance in front of analyzer is 304 mm (12 in.)
- Enclosures are NEMA 3R (IP 42), 316 SST.
- Instrument quality air only: 490 to 700 kPa (70 to 100 psig) Consumption: Normal operation - 4m³/hr

AMETEK
 PROCESS INSTRUMENTS
 WESTERN RESEARCH

2876 Sunridge Way N.E., Calgary, AB T1Y 7H9
 Ph. 403-235-8400, Fax 403-248-3550
www.ametekpi.com



© 2006, by AMETEK, Inc.
 All rights reserved. Printed in the U.S.A.
 880 (05/02/07)

One of a family of innovative process analyzer solutions from AMETEK Process Instruments.
 Specifications subject to change without notice.

SALES AND MANUFACTURING:

USA - Delaware
 455 Corporate Blvd., Newark DE 19702 • Tel: 302-456-4400, Fax: 302-456-4444
USA - Oklahoma
 2001 N. Indianwood Ave., Broken Arrow OK 74012 • Tel: 918-250-7200, Fax: 918-459-0165
USA - Pennsylvania
 150 Freepoint Road, Pittsburgh PA 15238 • Tel: 412-828-9040, Fax: 412-826-0399

WORLDWIDE SALES AND SERVICE LOCATIONS:

USA - Texas
 Tel: 281 463 2820, Fax: 281 463 2701
CHINA
 Beijing / Tel: 86 10 8526 2111, Fax: 86 10 8526 2141
 Chengdu / Tel: 86 28 8675 8111, Fax: 86 28 8675 8141
 Shanghai / Tel: 86 21 6426 8111, Fax: 86 21 6426 7818
FRANCE
 Tel: 33 1 30 68 89 20, Fax: 33 1 30 68 89 29
GERMANY
 Tel: 49 21 59 91 36 0, Fax: 49 21 59 91 3639
MIDDLE EAST - Dubai
 Tel: 971 4 881 2052, Fax: 971 4 881 2053
SINGAPORE
 Tel: 65 6484 2388, Fax: 65 6481 6588

WESTERN RESEARCH